

Asymmetrical Trim Guide

Your new Quantum asymmetrical is designed and engineered to be easy to set and trim. Fundamental principals of asymmetrical trim are outlined in this guide. For more detailed information, contact a Quantum Sail Consultant.

What makes an Asymmetrical Spinnaker different from a standard spinnaker?

First, geometry; an Asymmetrical has a distinct luff and leech. The tack is always the tack, and both sheets are tied onto the same corner (the clew),

An Asymmetrical Defined

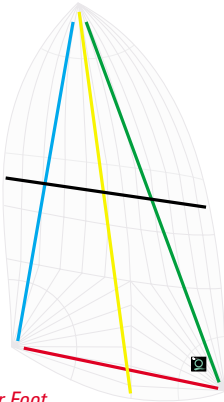

SF = Spinnaker Foot

SLU = Spinnaker Luff Length

SLE = Spinnaker Leech Length

SMG = Spinnaker Median Girth

just like a genoa. Second, the cross-sectional shaping is usually not uniform and semi-circular, as it would be with a spinnaker, but asymmetric. The position of maximum camber (draft), is likely to be forward of 50%. An asymmetrical typically has a rounder entry (luff) and flatter exit (leech). In general, they are much

better reaching sails than conventional symmetrical spinnakers, though they can be designed for sailing at broad angles.

At what wind angles can an asymmetrical be carried?

This is a function of design, materials, construction, and ultimately, of breeze velocity. The flatter and more genoa-like (asymmetrical in shape) the sail is, the closer to the wind it can be carried. More symmetrical (spinnaker-like) shapes are used in larger, fuller sails, to optimize them for broad reaching and running. The trick is to strike the right balance for the intended usage, or to have several asymmetricals with different purposes. The lighter the air, the closer to the wind you will be able to sail, regardless of the design.

Angles as close as 50 degrees apparent are not uncommon in less than 9-10 knots of wind. The problem for most asymmetricals, particularly on conventional displacement mono-hulls, comes in 10-14 knots of breeze when trying to sail at broader angles, (more than 135 degrees apparent). At these angles and velocities the sail has trouble being blanketed by the main-



sail. Modern asymmetricals tacked to the stem are designed to rotate area to weather of the centerline. This is the range where having a spinnaker pole, and the ability to pull the tack to weather out from behind the mainsail, pays off. Like all spinnakers, in more wind asymmetricals stay full and pressurized at broader and broader angles.

Quantum makes three basic asymmetrical spinnaker designs for cruising:

- v0 – Small, genoa like, optimized for close reaching and for sailing nearly upwind.
- v3 – All-Purpose, full sized, provides best broad reaching and running performance.
- v5 – Our most versatile sail similar to the v3 but in a smaller, flatter package. It is best for close reaching in light to moderate conditions, capable of broad reaching and running in all conditions.

What equipment do I need?

- Spinnaker halyard that is above the forestay.
- Tackline led through a block mounted forward of the headstay,

and aft to convenient cleat.

- Two sheets (approx. twice the length of the boat), led aft to blocks just forward of the stern pulpit.

Rigging an Asymmetrical

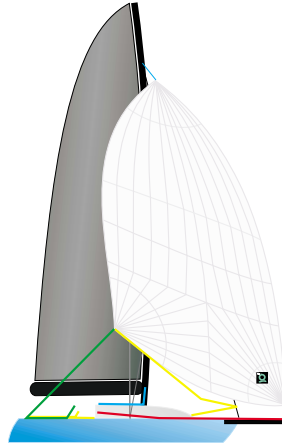

*Halyard – Attached to head.
Tack line – Attached to the tack.
Leeward (Lazy) Sheet – Attached to clew and led "outside all rigging" and aft to block on the quarter.*

If racing, or simply optimizing performance at broad angles, a spinnaker pole and afterguy can be used to control the tack of the sail, and allow it to be pulled aft at broader angles, just as with a conventional spinnaker. If a pole is used, a tack downhaul (or bobstay) will still need to be used.



Sets

- Set on a broad reach, where the mainsail will blanket the sail.
 - Secure bag near the middle of the foredeck.
 - Attach both sheets to the clew, leading the lazy sheet around in front of the headstay.
 - Attach downhaul. If there is a bowsprit, lead the downhaul over the sheets (inside jibes), if no bowsprit, lead downhaul under sheets (outside jibes).
 - Attach halyard, making sure halyard is outside and in front of the headstay.
- Pre-pull the downhaul so that the tack will be 3-4' off the deck.
 - but pre-pull the clew back to the shrouds.
 - Hoist rapidly.
 - When the sail is fully hoisted, trim the sheet.

A spinnaker sock may be used to keep the sail from filling while you hoist. If using a sock, secure the sock control lines to the mast after hoisting.

Setting

Broadreach

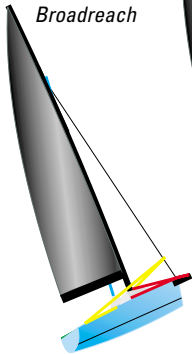

Hoist

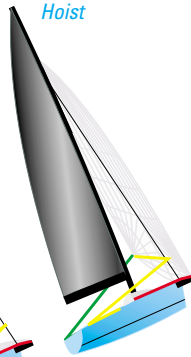

Pull tack to end of sprit, or until tack is 2-4' above the stem.

Trim sheet and adjust course to fill.

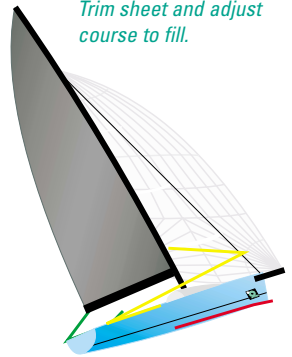

Trim

Ease the sheet out until the sail luffs (curls) along the leading edge. Trim in just enough to stop luffing. A periodic curl is good; this indicates the sail is just on the edge of luff. As with all sails, over-trimming is the most common problem. When in doubt, let it out.

For reaching, tighten the downhaul and lower the tack to pulpit height to minimize luff sag. This will pull the camber (draft) forward and open the leech. The tighter the downhaul, the more



Twing Setup

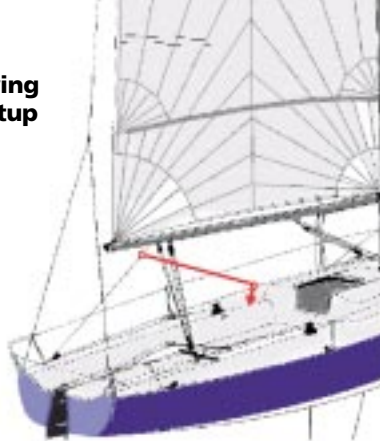

genoa-like the shape will be. Though it is a function of breeze velocity and the design range of the sail, in lighter winds you can use most asymmetricals as close as 50 degrees apparent wind angle. For running and broad reaching, ease the downhaul, allowing the tack to float up 4-6' off the deck. This will allow the sail to lift up, and the luff to rotate out to weather, away from the blanketing effect of the mainsail. It will also create a more spinnaker-like (symmetrical) shape.

If using a spinnaker pole to control the tack, set the pole just above the pulpit for close reaching. Gradually bring the pole aft, keeping it perpendicular to the apparent wind angle (just as with a symmetrical sail), and raising it gradually to keep the tack approximately level with the clew.



Jibing

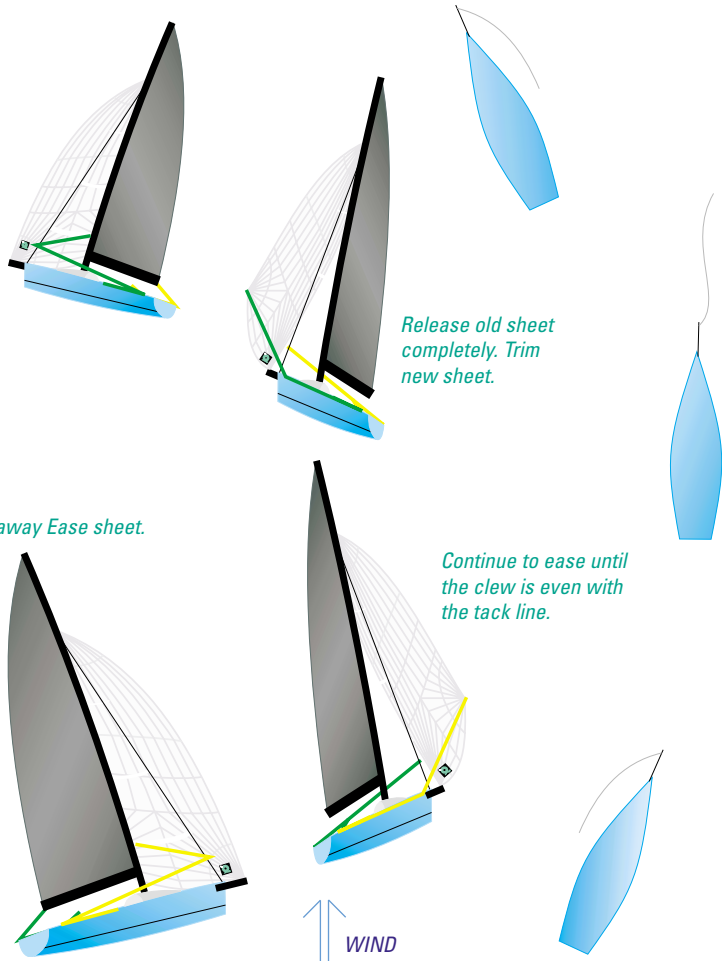

Another useful technique at broader angles is to “twing”, or move the sheet lead forward. (See diagram). This keeps the clew from rising up and dumping off

the leech, making the sail more symmetrical and powerful.

How deep (broad) an angle you can sail is largely a function of breeze



velocity. The lighter the air, the higher the angle (closer to the wind) you will need to sail to keep the asymmetrical full and pulling. To find the optimum angle for a given breeze velocity, start with sail full and pulling and bear off slowly till the clew begins to droop and the sheet begins to lose pressure, then head back up till the sail is solid and fully pressurized. This magic edge changes with velocity. You will be able to sail lower angles in the puffs, but will have to head up in the lulls.

Jibes

Asymmetrical spinnakers are jibed, not tacked. Start with sail fully loaded. Bear off slowly, easing the sheet as smooth and fast as you can without collapsing the sail. The trick is to use the sheet pressure to get the sail out in front of the boat. If the sail is not eased out before the boat gets downwind, it will collapse and fall into the headstay. As the boat passes through dead downwind, release the old sheet completely and take up on the new sheet. The sail is jibed outside and in front of the headstay when the tack

is set on the stem. If you have a long enough bowsprit, you can jibe inside the tack downhaul. No matter which system you use, turn from a broad reach to a broad reach slowly but smoothly. Do not stop in the middle of the turn, or you will encourage the sail to get wrapped around the headstay. Watch the sail and slow the turn slightly as the sail gets the clew gets to the headstay and is pulled around. The lighter the air, the higher the reaching angle you will need to sail, both at the outset, and as you exit the jibe. In very light air, you may have to physically help the sail around the headstay.

Take Downs

1. Bear off to a broad reach (10-20 degrees up from a dead-run is best).
2. Grab the lazy sheet just in front of the main boom.
3. Release the downhaul, or the active sheet, completely and gather the sail behind the mainsail using the lazy sheet.
4. Ease the halyard as fast as the sail can be gathered.

more on back page >



Take Downs

Release halyard and pull asymmetrical down behind main.

Overtrim sheet until clew is behind main.

Bear off to Broad Reach

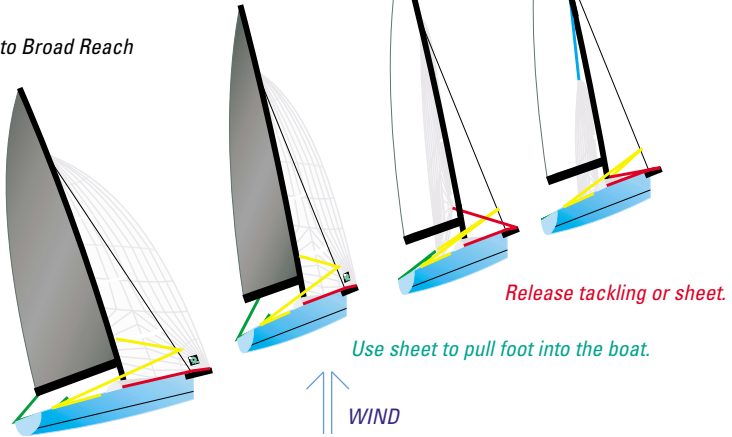

Release tacking or sheet.

Use sheet to pull foot into the boat.

5. Stuff the sail down the companionway or forward hatch as you gather. Putting the sail in the bag later is easier than trying to do it on deck if there is much breeze.

A spinnaker sock can be pulled down over the sail first to keep the sail from blowing out of control while being gathered. Release the sheet, and pull the sock down, then gather.

Racing take downs can be done in two other variations. First, a weather take down, where the lazy or a special take down line is led around the

headstay. The sheet is released, and the sail is pulled around the headstay to weather and gathered.

Another option is the "envelope" drop. Here, the lazy sheet is brought completely around to the leeward side and led through the foot of the mainsail (works with loose-footed mainsails only). The tack is released completely and the sail is gathered through the foot of the mainsail and down the main companionway hatch. This type of take down is particularly effective in windy situations on bigger boats.

